

# Protection Adapter

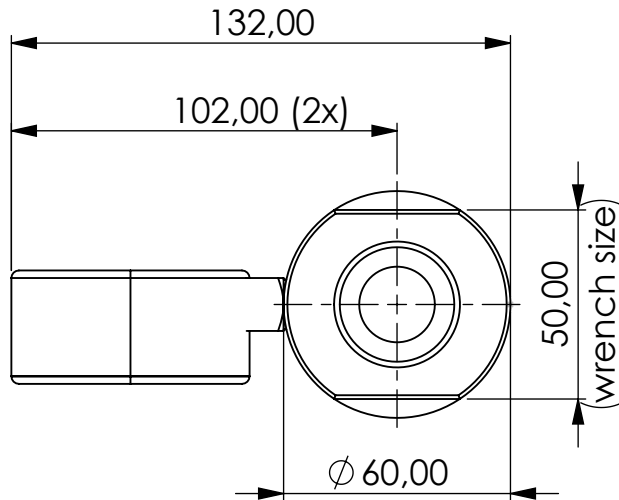
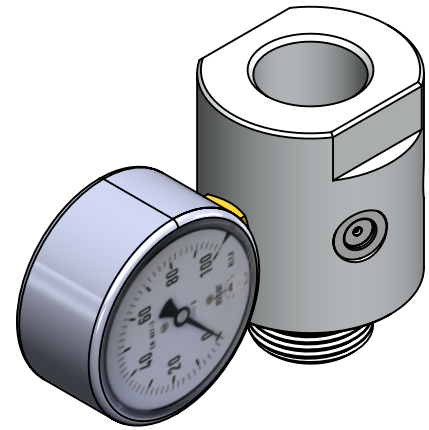

Contamination indicator for cases of blockage (100mbar).  
Optically

- Pressure gauge (up to 100mbar)

Additional check valves (2x IN / 2x OUT) for safety pressure release at 0,07bar

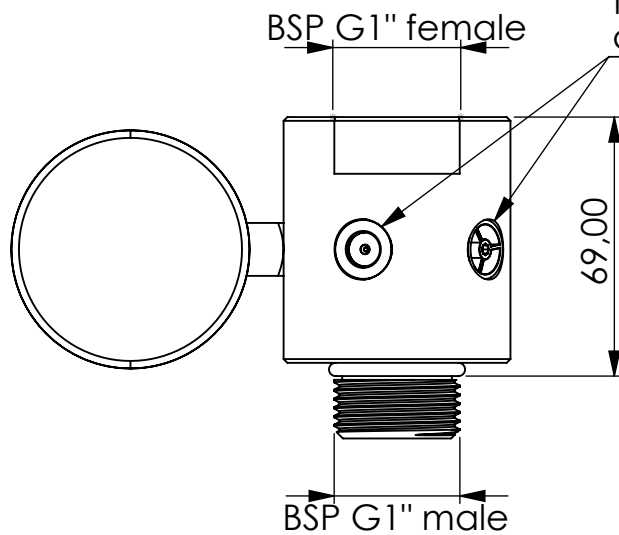

Product Code	PRT	-	AD	-	SS	-	F	-	F0,1-ma_V0,07	-	G1f	-	G1m
	Protection Adapter		Adapter female-male		Material stainless steel		FKM seals		Manometer 0,1bar + check valves 0,07bar		Connection for Adsorber BSP G1" female		Connection for Adsorber BSP G1" male

Total weight (kg): 0.49

NAME:

**Protection Adapter**  
PRT-AD\_AL\_F\_F0,1-ma\_V0,15\_G1f\_G1m

Article no.:  
**08.2104.15**

Status approved

Format A4

Ratio 1:2

Sheet / of 1 / 1



**GIEBEL Adsorber®**  
...setting standards in aeration drying!

GIEBEL FilTec GmbH  
www.giebel-adsorber.de  
info@giebel-adsorber.de